

УДК: 339.138:004.89=811.111

<https://doi.org/10.32342/3041-2137-2025-2-63-14>

Simran Babu,

Research Scholar (PhD), Department of Business Administration,
Sambalpur University, Burla, Sambalpur (India)

<https://orcid.org/0009-0000-2098-5802>

Saroj Kumar Sahoo,

PhD (Management), Assistant Professor, Department of Business Administration,
Sambalpur University, Odisha (India)

<https://orcid.org/0000-0001-7243-9491>

Oleksandr Zadoia,

PhD (Economics), Associate Professor,
Associate Professor of Global Economics Department,
Alfred Nobel University, Dnipro (Ukraine)

<https://orcid.org/0000-0002-4251-3061>

CONTEXTUALIZING ATTITUDE-INTENTION- BEHAVIOUR TRIAD WITH GREEN MARKETING & SUSTAINABLE PRACTICES: AN ISM APPROACH

Purpose: Although the relationship between behavioural intention and certain behaviour is a widely proven fact, the context in which this relationship develops has yet to be explored. Therefore, this study aims to examine the contextual relationship between green purchase behaviour and green purchase intention, customers' attitudes towards green shopping, customers' culture, customers' awareness of sustainable practices, perceived risk, and socio-demographic factors.

Research methodology & design: This study followed a qualitative approach, where the contextual relationships of the above-mentioned factors were studied with the ISM (Interpretive Structural Modelling) technique. An extensive literature review and opinions of some experts enabled the authors to establish the contextual relationships among the identified variables/elements.

Findings: The major findings indicate that green purchase behaviour is driven by the other aforementioned elements including the green purchase intention and attitude. The socio-demographic variables carry highest driving power, suggesting that these variables form the ground for above-mentioned intention and behaviour.

Originality: The new structural model based on contextual relationships makes a significant contribution to the existing theories and concepts related to the attitude-intention-behaviours triad.

Practical & social implications: A clear understanding of the aforementioned triadic relationship can provide innovative pathways for marketing strategies, with maximum consideration for the economy and society at large. The newly developed model also provides strategic inputs to the public planners for sustainable practices in the society.

Limitations & Implications: Empirical testing of the model with psychometric properties can provide wider applicability of this study.

Keywords: *Purchase-behaviour, Intention, Attitude, Green-shopping, Sustainable-awareness, Socio-demographic*

JEL classification: *M31, M38, Q51, Q57*

Мета: Хоча взаємозв'язок поведінкових намірів із певною поведінкою є широко доведеним фактом, контекст, у якому розвивається зазначений зв'язок, ще належить дослідити. Таким чином, це дослідження має на меті вивчити контекстуальний зв'язок поведінки «зелених» покупок із наміром «зелених» покупок, ставленням покупців до «зелених» покупок, культурою покупців, обізнаністю клієнтів щодо екологічних практик, сприйнятим ризиком і соціально-демографічними факторами.

Методологія та дизайн дослідження: Це дослідження дотримувалось якісного підходу, де контекстуальні зв'язки вищезгаданих факторів вивчаються за допомогою техніки ISM (інтерпретаційне структурне моделювання). Широкий огляд літератури та думки деяких експертів дозволили авторам побудувати контекстуальні зв'язки між ідентифікованими змінними/елементами.

Висновки. Основні висновки свідчать про те, що поведінка щодо екологічних покупок визначається іншими вищезазначеними елементами, включаючи намір і ставлення до екологічних покупок. Соціально-демографічні змінні мають найбільшу рушійну силу, що дозволяє зробити висновок, що ці змінні формують основу для вищезгаданих намірів і поведінки.

Оригінальність: Нова структурна модель, заснована на контекстуальних зв'язках, робить значний внесок у існуючі теорії та концепції, що стосуються тріади «ставлення-намір-поведінка».

Практичні та соціальні наслідки: Чітке розуміння згаданого тріадичного зв'язку може забезпечити інноваційні шляхи для маркетингових стратегій, що мають максимальне значення для економіки та суспільства в цілому. Розроблена модель також робить стратегічний внесок для державного планування сталого розвитку суспільства.

Обмеження та наслідки: Емпіричне тестування моделі з психометричними властивостями може забезпечити ширшу застосовність цього дослідження.

Ключові слова: *купівельна поведінка, намір, ставлення, зелений шопінг, стійка обізнаність, соціально-демографічні*

JEL classification: *M31, M38, Q51, Q57*

1. Introduction

Over the years, the meaning of 'greenness' to consumers has transformed in tandem with the growing priority placed on environmental sustainability. Fundamentally, green marketing still underlies the terms like value, naturalness, recyclability, health benefits, cleanliness, responsible conduct, and essential advantages. Notably, recent interviews indicate that the concept of greenness can be associated with trends in globalization, levels of education, and social standing [1], and those who perceive themselves as sustainable consumers typically uphold stronger ethical values and align with liberal perspectives. They demonstrate a deep concern for both environmental and social sustainability issues, acknowledging the responsibility of all involved parties in promoting sustainability [2]. So, the influence of 'green' purchasing extends to other pro-environmental actions through a positive behavioural spillage, albeit

primarily impacting behaviours that are low cost [3]. Further, the connection between purchase intention and green buying behaviour is influenced by the willingness to pay a premium, where purchase intentions effectively translate into actual purchase behaviour, including the link between attitudes toward green purchases and actual behaviour [4]. However, insufficient environmental consciousness, pricing concerns, perceived risks, company reputation, trust issues, and reluctance to pay premiums have been recognized as hindrances. These factors contribute to a disparity between consumer attitudes and their actual green-buying behaviour [5]. Thus, it is essential to examine the following research problem.

1.1 Problem statement

Can a hierarchical relationship be established among customers' socio-demographic variables, culture, perceived risk, awareness towards sustainable practices, attitude towards green shopping,

and purchase intention as the drivers of green purchase behaviour?

1.2 Study's objectives

(i) To study the contextual relationship among customers' socio-demographic variables, culture, perceived risk, awareness towards sustainable practices, attitude towards green shopping, and purchase intention.

(ii) To examine the driving power and dependency power of the above-mentioned elements relating to the green purchase behaviour of customers.

(iii) To develop a model as the strategic input for green-marketing strategies and plans.

2. Research methodology and design

This study follows a qualitative approach along with qualitative data and technique, the ISM (Interpretive Structural Modelling). The contextual relationship (CR) of green purchase behaviour & intention on the context of socio-demographic is studied by adopting a descriptive research design, where extensive literature review from databases of SCOPUS and Web of Sciences, along with experts' opinion are considered. The above procedure leads the authors to develop a model based on the above-mentioned relationships, because the ISM approach is a system design method as developed by Warfield (1974) by executing the following steps:

Step 1: Elements affecting the system under consideration were identified by the authors.

Step 2: From the elements identified in the previous step, contextual relationships are developed.

Step 3: A structural self-interaction matrix (SSIM) was then developed by authors comprising of seven elements (SDF, CC, CAGS, CASP, PR, CGPI & CGPB), which indicates pair-wise relationships of elements of the system under consideration.

Step 4: The initial reachability matrix is developed from the SSIM and then the final reachability matrix derived by checking the transitivity. The transitivity of the contextual relation is a basic assumption made in ISM, that is, if a variable A is related to B and B

is related to C, then A is necessarily related to C.

Step 5: Then the level partitioning of the reachability matrix is done, where the elements are segregated into different levels.

Step 6: After obtaining the levels, a conical matrix is developed which depicts the dependence and driving power for each element.

Step 7: Based on the level partitioning, a digraph is drawn, where the rigid arrows indicate there is a direct relationship and dotted arrows signify there is an indirect relationship between the variables.

Step 8: To better understand the variables and their hierarchical relationships, MICMAC analysis is carried out.

3. Discussion along literature

ISM, being the qualitative research approach proceeds by exploring the contextual relations that are derived from literature review and experts' opinion. The reviewed literatures are systematically presented below to arrive at eight contextual relationships (CR).

3.1 Green purchase intention leads to green purchase behaviour

In today's consumer landscape, a company's sustainability efforts and environmental awareness plays a pivotal role in shaping consumers' green habits, serving as a critical factor to alter consumer mindset and preferences towards eco-friendly options [6], where there is a positive behavioural spillover from environmentally conscious purchasing towards the adoption of other pro-environmental actions. But this overflow mainly impacts lower-cost behaviours [3] and the presence of a stigma associated with green choices weakens this connection [7]. Further, environmental collective efficacy and knowledge directly influence the intention to make green purchases, along with recent new ecological paradigm [8], where green purchase intention has been identified as the key predictor of green purchase behaviour [9]. So, directly and indirectly consumers' green purchase intention is associated with green purchase behaviour.

Intention to make green purchases is strongly associated with environmental

concern, attitude towards green packaging, and willingness to pay a premium [10], where the said willingness [11] and intention to engage in green purchases along with habit of eco-friendly actions, influence green purchasing behaviour [12]. Moreover, both green purchasing intention and electronic word of mouth exerted a positive impact on buying behaviour [13]. So, improvement in environmental awareness, characteristics of green products, green promotion and pricing policies corresponds to the improvement in consumer behaviour towards green purchases [14]. On the other hand, green skepticism diminishes customers' environmental consciousness and concern that leads to detrimental effect on their intentions to purchase green products [15]. Thus, it is discovered that green purchase intentions effectively translate into green purchase behaviour [11], which gives rise to the following contextual relationship.

CR1: It is observed by discussing above literature that customer's green purchase intentions lead to their green purchasing behavior.

3.2 Attitude toward green-shopping leads to green purchase behaviour through green purchase intention

Consumers carry positive perception of green products with eco-labels, promotion, price, availability, and quality for green purchases [16] because consumers' environmental consciousness significantly influences their attitudes towards environmental issues and eco-social benefits, which in turn positively influence their green purchase behaviour [17]. So, it can be stated that attitudes towards green purchases influence actual consumer green purchase behaviour through the intention to engage in green purchases [4], where customers' purchasing attitudes and intentions are positively influenced by green predictors like eco-literacy and biospheric values [18].

Increase in environmental consciousness, green product characteristics, green promotion, and green pricing can significantly increase the green purchasing behaviour [14]. Along with high environmental concern, less scepticism

exhibits a positive attitude, high subjective norm, and perceived behavioural control develops stronger green-intentions [19]. So, both the experiential & instrumental attitudes towards environmental friendliness, along with injunctive norms & descriptive norms related to environmentally friendly behaviour, green perceived control, and self-efficacy in green actions influence intentions towards environmentally conscious purchases [12]. Yet, factors like limitation in environmental awareness, pricing, perceived risks, corporate image, trust, and willingness make discrepancy between consumer attitudes and their actual purchasing patterns of green products [5] as well as, the inconvenience of adopting green practices limits consumers' willingness to pay premium for green products [20]. Moreover, green attitudes directly and positively influence purchase intention being moderated by price sensitivity and emotions related to environmental protection [21].

Thus, the value that green customers place on environmentally friendly products strongly influences their attitude toward these products, which subsequently drives their intention towards actual green-purchase [22], where intentions to purchase green products are notably influenced directly and indirectly, by attitudes toward green products, environmental concern, and perceived consumer effectiveness, with the latter two exerting their impact through the mediating role of attitudes toward green products [9]. The above logical discussions through literature urge this study to develop the following two contextual relationships.

CR2: Discussion of literature supports that there is a linkage between customers' attitudes toward green-shopping and their green purchase intention.

CR3: It is observed through discussion of above literature that there is an indirect connection between customers' attitude toward green-shopping and their green purchase behavior.

3.3 *Relationship of customers' awareness of sustainable practices with green purchase behaviour, and customers' attitude towards green-shopping*

Consumers' preference towards ecological products over the conventional products is driven by their adherence to green principles, familiarity with eco-friendly offerings & practices, and consumers' perceptions about organization's dedication to green marketing [23]. Complementary results suggest that awareness of eco-labeling, not just the environmental knowledge encourage consumers to engage in greener purchasing habits [24], as consumers with extensive environmental knowledge and significant peer influence tend to exhibit stronger intentions to become sustainable shoppers [25]. Yet, consumers remain reluctant to transition to eco-friendly products due to insufficient understanding of available options, limited product availability, rising prices, a scarcity of alternatives, and limited product varieties [26], and also, they are deterred from paying extra for green products due to the inconvenience associated with adopting eco-friendly practices [20]. Therefore, insufficient environmental awareness, pricing concerns, perceived risks, organizational image, trust, and unwillingness to spend are leading to a disparity between consumer attitudes and actual green-buying behavior [5]. So, the awareness about sustainable practices can be associated with green-purchase behaviour.

From organizations' perspectives, a company's exposure to sustainability and its responsiveness to environmental issues can significantly influence green consumer practices, and their preferences towards eco-friendly options [6]. This is because customers' awareness and related competitiveness influences sustainability capability and sustainable supply chain management [27]. So, the link between environmental attitudes and sustainable consumer behavior are driven by environmental knowledge, and awareness about benefits of sustainable design [28] and, the correlation between eco-labels and green purchase intention can be mediated by customers' green awareness and trust in environmentally conscious practices [29]. Therefore, it will be wise to infer that green-attitude can be meaningfully related to awareness about sustainable practices.

On the other hand, the level of environmental awareness can moderate the connection between environmental disclosure and customers' readiness to participate in eco-conscious consumption activities [6]. Moreover, environmental consciousness affects both green purchase attitude, which in turn influences perceived behavioral control and green purchase behavior [30] because environmental awareness, attributes of green products, green promotion and pricing strengthen the propensity for green purchasing behavior [14]. The above discussions can be logically led to following contextual relationship.

CR4: Consumers' awareness of sustainable practices can be meaningfully associated with attitude towards green shopping, and with green-purchase behaviour.

3.4 Customers' culture as context for green purchase behaviour through perceived risk

Customers are eco-conscious and concerned about protecting the environment. As a result, suppliers are responding positively to customers' heightened ecological awareness and their commitment to environmental conservation, which enhances supply chains with a customer-centric approach and minimizes environmental impacts [31]. Individuals who prioritize environmental conservation are adopting optimistic perspectives on sustainability and are leaning towards green methodologies [74]. Therefore, cultural aspects (self-transcendence/self-enhancement versus conservation/openness to change) and individual contextual factors (participation and face consciousness) can have varying impacts on consumers' perceived risk [32], as consumers' purchasing behavior is negatively related to perceived risk [33]. Further, consumer confidence, altruistic values, and subjective knowledge positively and significantly influence both green purchase behaviour and attitudes [34]. But government subsidies have lessened the detrimental impact of prices on green purchasing behaviour by reducing the

price differential between green products and their traditional counterparts [35] as doubts about green practices diminish customers' awareness and concern for the environment, subsequently reducing their willingness to purchase green products [15]. So, customers' cultural background can address the risk-perception of customers.

Customer loyalty is influenced by perceived risk, customer trust, and perceived quality of environmentally friendly products [36]. So, individuals who possess a strong environmental consciousness, accompanied by a sound understanding of environmental issues and solutions, are inclined to purchase environmentally friendly products when they have confidence in the attributes of the product and perceive their actions as contributing to environmental sustainability [37]. Therefore, functional value, social value, conditional value, and epistemic value along with moral identity of consumers emerge as key predictors of consumers' purchasing behaviour for environmentally friendly products [38]. Personality traits such as extraversion, agreeableness, conscientiousness, openness to experience, and neuroticism [39] as well as feeling competence and motivated to adopt green-purchase behaviour [24] exhibit correlations with green consumption. Additionally, community interactions related to green information exchange and interpersonal engagement on environmental issues contribute positively to consumers' experiences of both positive and negative environmental emotions, which are in turn, have favourable impact on consumers' green purchasing behaviours [40]. Thus, there are associations between perceived risk and green purchase behaviour [41; 42], which urge this study to derive the following contextual relationships.

CR5: It is observed by discussing the above literature that there is a strong connection between customers' culture and perceived risk.

CR6: Discussion of above literature gives an inference that there is an indirect connection between customers' culture and green purchase behavior.

3.5 Relationship of culture of customer with their green purchase intention, and with customer's attitude towards green-shopping

Consumers' lifestyles have dramatically changed, making them prefer environmentally friendly products over others, and they are often willing to pay a little extra for them [43]. Consumers worldwide are increasingly concerned about environmental sustainability, which makes the demand rise continuously for eco-friendly products paving the way for a greener future [44]. Thus, customer altruism positively influences consumer intent to purchase, fidelity, and outreach for green brands, potentially bridging the value-action gap [45]. Additionally, other cultural indicators like terminal and instrumental values [46], components of green advertising including viewers' attitudes [47] have significant effect on green attitude that in turn influences green behavioural intentions.

Green marketing mix has significant effect on green product purchase intention through the mediation of consumer-attitude [48], where quality and trust have a significant influence on customer attitudes and fidelity [49] with the green-marketing strategy. Several studies demonstrate psychological and social factors underlying customer culture as predictors of green attitudes and intentions. Attitude towards green-product [21] along with social norms and concern for the environment have a positive impact on customers' intentions to purchase eco-friendly goods [50]. Green psychological benefits and green advertising play a significant role in shaping the relationship between consumer attitudes, green customer value, and the green marketing mix in influencing green purchasing intentions [51]. Green product trust and perception positively impact green purchase intention, where green product experience, subjective norms, and perceived environmental protection value influence green product perception [52]. Eco-literacy and biospheric values positively impact the purchasing attitudes and intentions of millennial customers [18]. So, cultural values like collectivism, a long-term perspective, man-nature orientation

[53], components of moral intelligence like compassion, forgiveness, accountability, and integrity [54] play important role in increasing green purchase intention.

Furthermore, a person's social network may recommend, create, disseminate, and encourage a «norm» of positive environmental behaviour [55]. Therefore, customers' cultural values have an impact on their green purchasing intentions, both directly and indirectly [56]. Thus, the following contextual relationship can be derived.

CR7: It is observed through literature review that there is a strong connection of customers' culture with their attitude towards green shopping; but not with green purchase intention.

3.6 Socio-demographic factors lead to customer awareness of sustainable practices and to the culture of customer

Individuals who identify as sustainable consumers tend to exhibit elevated ethical perspectives, possess more feminine characteristics, lean towards liberal ideologies, and show significant interest in environmental and social sustainability matters [2]. Even, consumers' attitude and participation in online co-creation are influenced by deterrents and motivators, where motivation & attitude are influenced by cultural context, age, gender, educational level, individualism, masculinity, and low uncertainty avoidance [57]. Further, female consumers tend to exhibit a more favourable stance toward buying green products compared to their male counterparts [58] where internal (demographic and psychographic) as well as external (cultural and social) factors strongly influence women's purchasing behaviour [59]. And, women & older individuals tend to hold more favourable attitudes toward environmental sustainability concerning events [60]. Therefore, socio-cultural and demographic elements, notably openness to new cultures, conservatism, and fatalism, are closely linked to consumers' ethnocentric tendencies [61].

Attitudes of consumers towards sustainable practices are influenced by factors such as country of residence, level of education, and income level [62], where

customers' environmentally friendly attitudes are linked to their stated eco-friendly intentions that influenced by past experiences and do not vary substantially according to age, education, and household income [63]. However, some studies suggest that consumer behavior is influenced by perception, age, gender, and income [64]. For instance, age along with marital status significantly impact the willingness to pay more for eco-friendly products, [65]; gender, income, and age make variations in customer awareness and desire for eco-friendly hotels [66]; age, gender, and level of education play a vital role in amplifying and reinforcing the connection of green marketing practices with perceptions about green products, purchase intentions, consumer purchasing decisions, and environmental awareness [67] and green behaviour [68]. Finally, socio-demographic factors influence both awareness and purchase behaviour for green products [58]. So, the above studies justify the relevance and association of demographic variables with sustainable practices. The above two paragraphs of discussions lead to the following contextual relationship.

CR8: There is a direct relationship customers' sociodemographic factors with their culture; and with their awareness of sustainable practices

4. Analysis & discussion

Based on the contextual relationships between elements, ISM technique proceeds. For each pair of elements (i and j), a relationship is evaluated to determine the direction of influence, according to the following rules. Four symbols (rules) are used to denote the direction of the relationships between the elements.

'V'- if i leads to j; 'A'- if j leads to i; 'X'- if i and j both relate to each other; 'O'- if i and j are not related to each other. Hereby, the SSIM (table-1a) is converted to the initial reachability matrix (Table 1b) according to the rules of ISM, that is 'V' and 'X' are denoted by 1, and 'A' and 'O' are denoted by 0. After which, the initial reachability matrix is converted to the final reachability matrix (Table-1b) where transitive relationships among elements are shown as 1*.

Table 1

SSI matrix of green purchase behaviour and reachability matrices

1a: SSI matrix of green purchase behaviour								1b: Reachability matrices (Initial/Final)							
I \ J	CC	CAGS	CASP	CGPI	CGPB	PR	SDF	CC	CAGS	CASP	CGPI	CGPB	PR	SDF	
CC	■	V	O	V	O	V	A	1	1	0	1	0/1*	1	0	
CAGS	■	■	A	V	O	O	A	0	1	0	1	0/1*	0	0	
CASP	■	■	■	V	V	O	A	0	1	1	1	1	0	0	
CGPI	■	■	■	■	V	A	O	0	0	0	1	1	0	0	
CGPB	■	■	■	■	■	A	O	0	0	0	0	1	0	0	
PR	■	■	■	■	■	■	O	0	0	0	1	1	1	0	
SDF	■	■	■	■	■	■	■	1	1	1	0/1*	0/1*	0/1*	1	

Source: Authors' compilation from analysis

The reachability matrix was then partitioned into levels and the elements were organized as per levels after all the iterations [69] based on the reachability set, antecedent set, and interaction set for each of the elements (table 2).

Elements sharing the same reachability set and intersection set are designated as

level I and positioned at the topmost level in the hierarchy. Afterward, this element is excluded from the set. This procedure continues iteratively until all elements are classified into distinct hierarchical levels.

Conical matrix (table 3) is prepared based on the final-reachability matrix, combining variables at same level across rows

Table 2

Level Partition of seven elements of the study

Dimension	Reachability	Antecedent	Interaction	Level
Iteration 1				
Customer culture	1,2,4,5,6	1,7		
Customer attitude towards green shopping	2,4,5	1,2,3,7		
Customer awareness of Sustainable practices	2,3,4,5	3,7		
Customer green purchase Intention	4,5	1,2,3,4,6,7		
Customer green purchase behavior	5	1,2,3,4,5,6,7	5	I
Socio-demographic factors	1,2,3,4,5,6,7	7		
Perceived risk	4,5,6	1,6,7		
Iteration 2				
Customer culture	1,2,4,6	1,7		
Customer attitude towards green shopping	2,4	1,2,3,7		
Customer awareness of Sustainable practices	2,3,4	3,7		
Customer green purchase Intention	4	1,2,3,4,6,7	4	II
Socio-demographic factors	1,2,3,4,6,7	7		
Perceived risk	4,6	1,6,7		
Iteration 3				
Customer culture	1,2,6	1,7		
Customer attitude towards green shopping	2	1,2,3,7	2	III
Customer awareness of Sustainable practices	2,3	3,7		
Socio-demographic factors	1,2,3,6,7	7		
Perceived risk	6	1,6,7	6	III
Iteration 4				
Customer culture	1	1,7	1	IV
Customer awareness of Sustainable practices	3	3,7	3	IV
Socio-demographic factors	1,3,7	7		
Iteration 5				
Socio-demographic factors	7	7		V

Source: Authors' compilation from analysis

Table 3

Conical matrix

i/j	3	4	2	6	5	7	1	Driving Power	Level
CGPB (3)	1	0	0	0	0	0	0	1	I
CGPI (4)	1	1	0	0	0	0	0	2	II
CAGS (2)	1*	1	1	0	0	0	0	3	III
PR (6)	1	1	0	1	0	0	0	3	III
CASP (5)	1	1	1	0	1	0	0	4	IV
CC (7)	1*	1	1	1	0	1	0	5	IV
SDF (1)	1*	1*	1	1*	1	1	1	7	V
Dependency Power	7	6	4	3	2	2	1		
Level	I	II	III	III	IV	IV	V		

Source: Authors' compilation from analysis

and columns of the final reachability matrix, where the driving power is determined by summing up all ones in the rows and the dependency power is determined by summing up all ones in columns. The elements with higher dependency power and lower driving power are placed at level 1. Similarly, other elements are placed in different levels based on their driving and dependency power.

Based on the reachability matrix, the digraph is drawn. The rigid arrow marks signify a direct relationship between the elements and the dotted arrow marks indicate indirect relationships. The digraphs are examined interactively to eliminate transitive

relationships. After addressing the transitive relationships, the digraph is finalized as ISM model.

The MICMAC analysis (figure-2) is done for the author's better understanding. It analyses the driving and dependency power of the elements. The elements are categorized into four quadrants. The first quadrant consists of autonomous elements such as perceived risk (PR), which have weak driving power and weak dependence. The second quadrant consists of dependent elements, namely Customers' Attitudes towards Green Shopping (CAGS), Customers' Green Purchasing Intention (CGPI), and

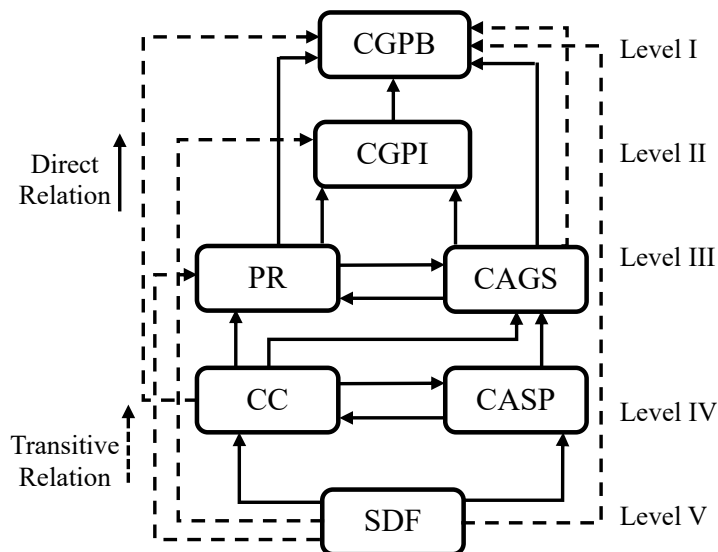

Fig. 1: Digraph

Source: Authors' compilation from analysis

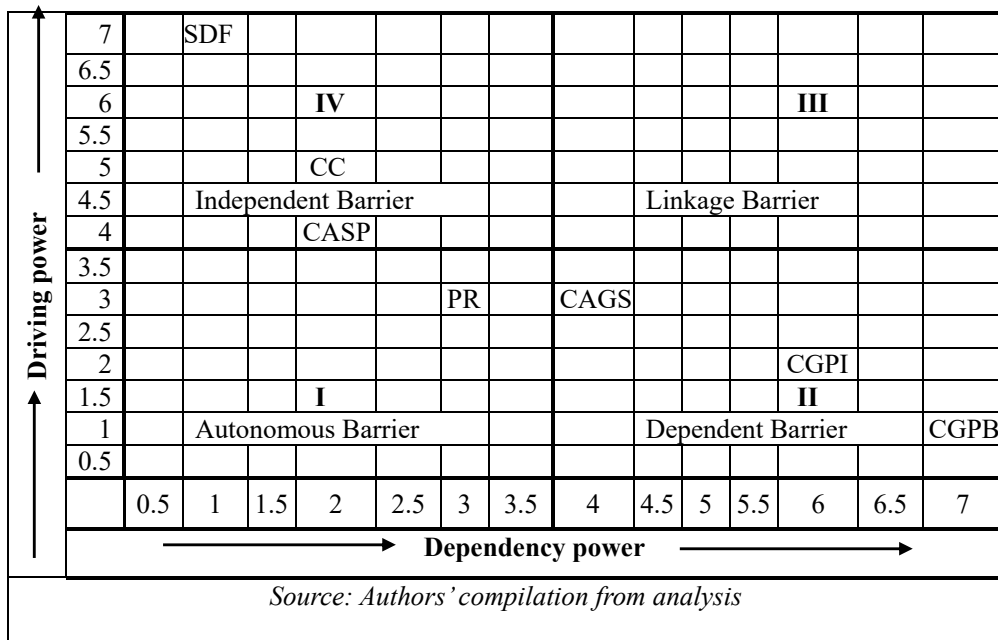

Fig.2. MICMAC Analysis

Customers' Green Purchase Behaviour (CGPB), which have weak driving power but strong dependency. The third quadrant consists of linkage elements that have both strong driving power and dependency power. The fourth quadrant consists of independent elements, namely Customers' Awareness of Sustainable Practices (CASP), Culture of Customer (CC), and Socio-demographic Factors (SDF), which have strong driving power and weak dependency.

5. Findings & implications

The widely accepted and proven relationship between actual behavior and its preceding stage – behavioral intention – as proposed by the Theory of Reasoned Action [70; 71] and the Theory of Planned Behavior [72; 73], is also validated in the present study within the context of green marketing. Consumers' green purchase behaviour (CGPB) carrying highest dependency power is driven by consumers' green purchase intention (CGPI), as illustrated in the digraph at level I and level II respectively.

The drivers of consumers' green purchase intention are explored as perceived risk (PR), consumers' attitude towards green shopping (CAGS), consumers' culture

(CC), consumers' awareness of sustainable practices (CASP), and sociodemographic factors (SDF) of the concerned consumers, as shown in the digraph, where SDF carry highest driving power and lowest dependency power. This outcome implies that socio demographic variable can serve as the ground (context) for making intention favourable towards the green shopping.

Examining the relationship among PR, CAGS, CC, and CASP, it can be inferred that CC and CASP are driving PR and CAGS which, in turn, are driving green purchase intention, and purchase behaviour sequentially. This outcome is further substantiated by another result: that customers' culture and their attitude towards green shopping are indirectly driving green purchase behaviour. Therefore, a positive attitude towards green shopping can be enhanced, and the negative effect of perceived risk can be reduced, if the customers' culture is conducive towards favourable attitude and less deteriorating perceived risk.

As the sociodemographic factors carry the highest driving power, they can be treated as the integral and non-avoidable element in building customers' conducive culture and

accelerate the awareness of customers for sustainable practices, which, over time, build a positive attitude of customers towards green shopping. Complimenting this finding, it can be inferred that sociodemographic factors of consumers are indispensable for green marketing and green shopping, because SDF is indirectly driving the green purchase behaviour, purchase intention, and perceived risk in the context of sustainability and green marketing.

5.1 Contextual triad of attitude-intention-behaviour

As proven through some well-accepted studies, “consumers’ attitude” forms “behavioural intention”, which ultimately leads to ‘actual behavior’ (the triad in this study). However, this cannot be uniformly accepted in every context, especially in purchase behavior. In the context of green purchase (Figure 1 and 2), consumers’ green attitude varies according to their cultural background and awareness about the sustainability that are in turn driven by socio-demographic factors of those consumers. Green-attitude also varies according to the consumers’ perceived risk, which is directly influenced by customer-culture and indirectly influenced by socio-demographic variables. So, the favourableness (or unfavourableness) of consumers’ attitude towards green product does vary in the presence of perceived risk (contextualized with perceived-risk), even if the other three factors remain the same as drivers of green attitude (contextualized with these three factors).

The rest of the two factors of triad are also contextualized with direct and indirect effects. The level of consumers’ green-purchase intention and green-purchase behaviour can vary directly according to the level of favourableness (or unfavourableness) of perceived-risk, and green-attitude of consumers; and indirectly according to their cultural background and socio-demographic factors. Hence, the level of effects of the triad (attitude-intention-behaviour of consumers) and its advantages (or disadvantages) for the marketers should be predicted specifically for different contexts. Further, the attitude and intention must be strategized differently

by the marketers in the varying contexts for the consumers’ desired behaviour. Thus, the triad of attitude-intention-behaviour cannot be universally applicable, rather, its applicability should depend on the compatible context.

6. Conclusion and contributions

This paper undertakes a thorough review of existing literature on the integration of Interpretive Structural Modeling (ISM) in the realm of green purchase behaviour (GPB). This review lays a solid foundation for identifying research agendas and offers clear guidance for scholars and researchers to develop, define, and identify their research directions in utilizing ISM methodology effectively. Furthermore, insights from the literature suggest that ISM facilitates the translation of vague and poorly expressed mental models of systems into tangible, well-defined models. This transformation proves invaluable in addressing the pertinent issues at hand. Additionally, ISM enables the depiction of a comprehensive hierarchy of variables in a graphical model, providing a structured approach for tackling the problem or issue under investigation.

The present study is conducted to ascertain the factors influencing Green Purchase Behaviour (GPB), with a particular focus on how sociodemographic factors affect green purchase behaviour & intention, which is the key contribution of this research work. The study identifies various variables that ultimately influence green purchase behaviour. Sociodemographic factors are positioned at the fifth level of the digraph, exerting influence on all other study variables. Customers’ culture and awareness of sustainable practices reside at the fourth level of the digraph, influenced by fifth-level variables, and in turn, affect variables across different levels. Perceived risk and customer attitude towards green shopping are situated at the third level, influenced by all variables from levels four and five. At the second level, customer green purchase intention is influenced by variables from levels five, four, and three, subsequently impacting green purchase behaviour at the first level, which serves as the dependent variable.

7. Limitations & future research avenues

Employing ISM (Interpretive Structural Modeling), a qualitative research design, makes this study limited to its ability to generate empirical evidence for the concept and model. Therefore, future researchers may opt for a quantitative approach to examine the structural relationships among

variables like sociodemographic factors, customers' culture, customers' awareness towards sustainable practices, perceived risk, customers' attitude towards green shopping, customers' green purchase intention, and customers' green purchase behaviour. Further, their psychometric properties can offer greater clarity and practical feasibility regarding the applicability of these relationships.

References

1. Lee, H.-S., and Hong, S. (2019), "Revisiting of Greenness to Consumers in Green Purchases", *Journal of Distribution Science*, Vol. 17 No. 10, pp.107 – 114. <https://doi.org/10.15722/jds.17.10.201910.107>
2. Tasci, A.D.A., Fyall, A., Woosnam, K.M. (2022), "Sustainable tourism consumer: socio- demographic, psychographic and behavioral characteristics", *Tourism Review*, Vol. 77 No. 2, pp.341-375. <https://doi.org/10.1108/TR-09-2020-0435>
3. Lanzini, P., and Thøgersen, J. (2014), "Behavioural spillover in the environmental domain: An intervention study", *Journal of Environmental Psychology*, Vol. 40, pp.381-390. <https://doi.org/10.1016/j.jenvp.2014.09.006>
4. Duong, C. D. (2024), "Environmental corporate social responsibility initiatives and the attitude-intention-behavior gap in green consumption", *Social Responsibility Journal*, Vol. 20 No. 2, pp.305 – 325. <https://doi.org/10.1108/SRJ-11-2022-0487>
5. Sharma, A. P. (2021), "Consumers' purchase behaviour and green marketing: A synthesis, review and agenda", *International Journal of Consumer Studies*, Vol. 45 No. 6, pp.1217-1238. <https://doi.org/10.1111/ijcs.12722>
6. Rustam, A., Wang, Y., Zameer, H. (2020), "Environmental awareness, firm sustainability exposure and green consumption behaviors", *Journal of Cleaner Production*, Vol. 268, 122016. <https://doi.org/10.1016/j.jclepro.2020.122016>
7. Khan, S. J., Chauhan, C., and Ul Akram, M. (2020), "Cognitive factors influencing green consumption behaviour of young millennials: An empirical check on Indian consumers", *International Journal of Green Economics*, Vol. 14 No. 4, pp.293 – 314. <https://doi.org/10.1504/IJGE.2020.112566>
8. Lee, Y. K. (2017), "A comparative study of green purchase intention between Korean and Chinese consumers: The moderating role of collectivism", *Sustainability (Switzerland)*, Vol. 9 No. 10, pp.1 – 17. <https://doi.org/10.3390/su9101930>
9. Jaiswal, D., Kant, R. (2018), "Green purchasing behaviour: A conceptual framework and empirical investigation of Indian consumers", *Journal of Retailing and Consumer Services*, Vol. 41, pp.60-69. <https://doi.org/10.1016/j.jretconser.2017.11.008>
10. Kashif, M., Rani, T. (2021), "Customers' attitude towards green packaging: a case of sapphire, Pakistan", *Journal of Marketing Strategies*, Vol. 3 No. 1, pp.1-28. <https://doi.org/10.52633/jms.v3i1.58>
11. Chaudhary, R., Bisai, S. (2018), "Factors influencing green purchase behavior of millennials in India", *Management of Environmental Quality*, Vol. 29 No. 5, pp.798-812. <https://doi.org/10.1108/MEQ-02-2018-0023>
12. Siddique, M. Z. R., Saha, G., & Kasem, A. R. (2021), "Estimating green purchase behavior: an empirical study using integrated behavior model in Bangladesh", *Journal of Asia Business Studies*, Vol. 15 No. 2, pp. 319 – 344. <https://doi.org/10.1108/JABS-04-2019-0120>

13. Kumar, A., and Pandey, M. (2023), “Social Media and Impact of Altruistic Motivation, Egoistic Motivation, Subjective Norms, and EWOM toward Green Consumption Behavior: An Empirical Investigation”, *Sustainability (Switzerland)*, Vol. 15 No. 5. <https://doi.org/10.3390/su15054222>
14. Boztepe, A. (2012), “Green Marketing and Its Impact on Consumer Buying Behaviour”, *European Journal of Economic and Political Studies*, Vol. 5 No. 1, pp.5-21.
15. Goh, S. K., and Balaji, M. S. (2016), “Linking green skepticism to green purchase behavior”, *Journal of Cleaner Production*, Vol. 131, pp.629 – 638. <https://doi.org/10.1016/j.jclepro.2016.04.122>
16. Amir, M., and Dhyani, A. (2019), “Measuring consumers’ perception and determinants of green purchase”, *International Journal of Advanced Science and Technology*, Vol. 28 No. 7, pp.250 – 269. <https://www.scopus.com/inward/record.uri?eid=2-s2.0-85081190579&partnerID=40&md5=5bf082ccb1eb6b6058596d471d9801d4>
17. Cheung, M. F. Y., and To, W. M. (2019), “An extended model of value-attitude-behavior to explain Chinese consumers’ green purchase behavior”, *Journal of Retailing and Consumer Services*, Vol. 50, pp.145–153. <https://doi.org/10.1016/j.jretconser.2019.04.006>
18. Tiwari, P. (2023), “Influence of Millennials’ eco-literacy and biospheric values on green purchases: the mediating effect of attitude”, *Public Organization Review*, Vol. 23 No. 3, pp.1195 – 1212. <https://doi.org/10.1007/s11115-022-00645-6>
19. Albayrak, T., Aksoy, Ş., and Caber, M. (2013), “The effect of environmental concern and scepticism on green purchase behaviour”, *Marketing Intelligence and Planning*, Vol. 31 No. 1, pp.27 – 39. <https://doi.org/10.1108/02634501311292902>
20. Singh, T. P., Khandelwal, U., & Yadav, S. K. (2019), “Assessing the spending tendency of consumers on green products: An Indian perspective”, *International Journal of Green Economics*, Vol. 13 No. 3–4, pp.218 – 234. <https://doi.org/10.1504/IJGE.2019.104509>
21. Lavuri, R. (2022), “Organic green purchasing: Moderation of environmental protection emotion and price sensitivity”, *Journal of Cleaner Production*, Vol. 368, 133113. <https://doi.org/10.1016/j.jclepro.2022.133113>
22. Liao, Y., Wu, W., and Pham, T. (2020), “Examining the moderating effects of green marketing and green psychological benefits on customers’ green attitude, value and purchase intention”, *Sustainability*, Vol. 12 No. 18, 7461, pp.1-19. <https://doi.org/10.3390/su12187461>
23. Bhatia, M., Jain, A. (2013), “Green Marketing: A Study of Consumer Perception and Preferences in India”, *Electronic Green Journal*, Vol. 1 No. 36, pp.1-20. <https://doi.org/10.5070/G313618392>
24. Adrita, U. W., and Mohiuddin, M. F. (2020), “Impact of opportunity and ability to translate environmental attitude into ecologically conscious consumer behavior”, *Journal of Marketing Theory and Practice*, Vol. 28 No. 2, pp.173–186. <https://doi.org/10.1080/10696679.2020.1716629>
25. Nagarajan, M., Saha, R., Kumar, R., and Sathasivam, D. (2022), “Impact of Peer Influence and Environmental Knowledge on Green Consumption: Moderated by Price Premium”, *International Journal of Social Ecology and Sustainable Development*, Vol. 13 No. 6.
26. Saxena, N.K. (2021), “Green consumerism and environmental sustainability: A study of attitude towards environment friendly products” *Indian Journal of Ecology*, Vol. 48, pp.12-17. <https://www.scopus.com/inward/record.uri?eid=2-s2.0-85113790239&partnerID=40&md5=b10b1a8a0377aacb539b17554cbc7a67>
27. Jermstittiparsert, K., Joemstittiprasert, W., and Phonwattana, S. (2019), “Mediating role of sustainability capability in determining sustainable supply chain management in tourism industry of Thailand”, *International Journal of Supply Chain Management*, Vol. 8 No. 3, pp.47 – 58. <https://www.scopus.com/inward/record.uri?eid=2-s2.0.085068209277&partnerID=40&md5=7cb6322f1abfad7a14fbce10d447bf6c>

28. Horani, L. F. (2020), "Identification of target customers for sustainable design", *Journal of Cleaner Production*, Vol. 274, pp.1-13. <https://doi.org/10.1016/j.jclepro.2020.123102>
29. Alamsyah, D., Udjaja, Y., Othman, N. A., and Ibrahim, N. R. W. (2020), "Green Customer Behavior: Mediation Model of Green Purchase", *International Journal of Psychosocial Rehabilitation*, Vol. 24 No. 5, pp.2568-2577. <https://doi.org/10.37200/IJPR/V24I5/PR201956>
30. Mishal, A., Dubey, R., Gupta, O. K., and Luo, Z. (2017), "Dynamics of environmental consciousness and green purchase behaviour: an empirical study", *International Journal of Climate Change Strategies and Management*, Vol. 9 No. 5, pp.682 – 706. <https://doi.org/10.1108/IJCCSM-11-2016-0168>
31. Zarei, M. M., Mokhtari, M., and Yusuff, R. M. (2014), "Review in supply chain base on green consumers attitude. *Applied Mechanics and Materials*, Vol. 564, pp. 706 – 710. <https://doi.org/10.4028/www.scientific.net/AMM.564.706>
32. Keh, H. T., and Sun, J. (2008), "The Complexities of Perceived Risk in Cross-Cultural Services Marketing", *Journal of International Marketing*, Vol. 16 No. 1, pp.120-146. <https://doi.org/10.1509/jimk.16.1.120>
33. Li, Z., Sha, Y., Song, X., Yang, K., ZHao, K., Jiang, Z., and Zhang, Q. (2019), "Impact of risk perception on customer purchase behavior: a meta-analysis", *Journal of Business & Industrial Marketing*, Vol. 35 No. 1, pp.76-96. <https://doi.org/10.1108/JBIM-12-2018-0381>
34. Gu, S. (2022), "The effects of subjective knowledge, altruistic value and consumer self-confidence on the green purchase attitudes and green purchase behaviour of Chinese customers", *Turyzm/Tourism*, Vol. 32 No. 2, pp.7 – 27. <https://doi.org/10.18778/0867-5856.32.2.01>
35. Guan, H.-J., Wang, H., and Zhao, A.-W. (2015), "Dynamic modeling and computational experiment of consumers' green purchase behavior", *Journal of Computational and Theoretical Nanoscience*, Vol. 12 No. 12, pp.6107 – 6113. <https://doi.org/10.1166/jctn.2015.4644>
36. Marakanon, L., Panjakajornsak, V. (2017), "Perceived quality, perceived risk and customer trust affecting customer loyalty of environmentally friendly electronics products", *Kasetsart Journal of Social Sciences*, Vol. 38 No. 1, pp.24-30. <https://doi.org/10.1016/j.kjss.2016.08.012>
37. Patharia, I., Rastogi, S., Vinayek, R., and Malik, S. (2020), "A fresh look at environment friendly customer's profile: Evidence from India", *International Journal of Economics and Business Research*, Vol. 20 No. 3, pp.310 – 321. <https://doi.org/10.1504/IJEBR.2020.110425>
38. Rana, S. M. S., and Solaiman, M. (2023), "Moral identity, consumption values and green purchase behaviour", *Journal of Islamic Marketing*, Vol. 14 No. 10, pp.2550 – 2574. <https://doi.org/10.1108/JIMA-01-2021-0030>
39. Duong, C. D. (2022), "Big Five personality traits and green consumption: bridging the attitude-intention-behavior gap", *Asia Pacific Journal of Marketing and Logistics*, Vol. 34 No. 6, pp.1123 – 1144. <https://doi.org/10.1108/APJML-04-2021-0276>
40. Wang, J., Yang, X., Xi, Y., & He, Z. (2022), "Is Green Spread? The Spillover Effect of Community Green Interaction on Related Green Purchase Behavior", *International Journal of Environmental Research and Public Health*, Vol. 19 No. 11, 6571. <https://doi.org/10.3390/ijerph19116571>
41. Sharma, N., Lal, M., Goel, P., Sharma, A., Rana, N. P. (2022), "Being socially responsible: How green self-identity and locus of control impact green purchasing intentions?" *Journal of Cleaner Production*, Vol. 357, 131895, <https://doi.org/10.1016/j.jclepro.2022.131895>

42. Sheikh, A., Mirzaei, M., & Ahmadinejad, B. (2023), "Factors Influencing Green Purchase Behavior: Price Sensitivity, Perceived Risk, and Attitude towards Green Products", *Contemporary Management Research*, Vol. 19 No. 3, pp.153–174. <https://doi.org/10.7903/cmr.22824>
43. Singh, P. B., Pandey, K. K. (2012), "Green marketing: policies and practices for sustainable development", *Integral Review - A Journal of Management*, Vol. 5 No. 1, pp.22-30. <http://dx.doi.org/10.13140/RG.2.2.23593.34403>
44. Saxena, R. P. & Khandelwal, P. K. (2009), "Green marketing: a challenge or an opportunity in the global environment", *Global Studies Journal*, Vol. 2 No. 3, pp.59-73. <https://ro.uow.edu.au/dubaipapers/336>
45. Panda, T. K., Kumar, A., Jakhar, S., Luthra, S., Garza-Reyes, J. A., Kazancoglu, I., and Nayak, S. S. (2019), "Social and environmental sustainability model on consumers' altruism, green purchase intention, green brand loyalty and evangelism", *Journal of Cleaner Production*, Vol. 243, 118575 pp.1-11. <https://doi.org/10.1016/j.jclepro.2019.118575>
46. Kautish, P., and Sharma, R. (2019), "Value orientation, green attitude and green behavioral intentions: an empirical investigation among young consumers", *Young Consumers*, Vol. 20 No. 4, pp.338 – 358. <https://doi.org/10.1108/YC-11-2018-0881>
47. Khandelwal, U., and Bajpai, N. (2011), "A Study on Green Advertisement and its Impact on Consumer Purchase Intention", *Journal of Creative Communications*, Vol. 6 No. 3, pp.259 – 276. <https://doi.org/10.1177/0973258613491661>
48. Kartawinata, B. R., Maharani, D., Pradana, M., and Amani, H. M. (2020), "The role of customer attitude in mediating the effect of green marketing mix on green product purchase intention in love beauty and planet products in Indonesia", *Proceedings of the International Conference on Industrial Engineering and Operations Management, August*. <https://www.scopus.com/inward/record.uri?eid=2-s2.0.085096590184&partnerID=40&md5=726e90e4aa6200e3c0584d1c050a0e0f>
49. Baktash, L., Talib, M. A. (2019), "Green Marketing Strategies: Exploring Intrinsic and Extrinsic Factors towards Green Customers' Loyalty", *Quality access to success*, Vol. 20 No. 168, pp.127- 134.
50. Rashid, I., and Lone, A. H. (2023), "Organic food purchases: does green trust play a part?", *Asia-Pacific Journal of Business Administration*. <https://doi.org/10.1108/APJBA-11-2022-0506>
51. Ahmed, R. R., Streimikiene, D., Qadir, H., and Streimikis, J. (2023), "Effect of green marketing mix, green customer value, and attitude on green purchase intention: evidence from the USA", *Environmental Science and Pollution Research*, Vol. 30 No. 5, pp.11473 – 11495. <https://doi.org/10.1007/s11356-022-22944-7>
52. Ye, P., Liu, L., Gao, L., & Mei, Q. (2021), "The effects of green product trust and perception on green purchase intention in China", *International Journal of Innovative Computing and Applications*, Vol. 12 No. 5–6, pp.263–272. <https://doi.org/10.1504/IJICA.2021.119304>
53. Nguyen-Thi-Phuong, A., Le-Kim, S., To-The, N., Nguyen-Thu, H., and Nguyen-Anh, T. (2023), "The influences of cultural values on consumers' green purchase intention in emerging markets: An evidence from South Korea and Vietnam", *Current Psychology*, Vol. 42 No. 34, pp.30293 – 30310. <https://doi.org/10.1007/s12144-022-04064-0>
54. Al-Adamat, A., Al-Gasawneh, J., and Al-Adamat, O. (2020), "The Impact of Moral Intelligence on Green Purchase Intention", *Management Science Letters*, Vol. 10 No. 9, pp.2063 – 2070. <https://doi.org/10.5267/j.msl.2020.2.005>
55. Hasan, S. A., Subhani, M. I., Osman, A. (2012), "The Crux of Green Marketing: An Empirical Effusive Study", *European Journal of Social Sciences*, Vol. 27 No. 3, pp.425-435. <https://mp.ra.ub.uni-muenchen.de/id/eprint/35688>

56. Hussain, S., and Huang, J. (2022), "The Impact of Cultural Values on Green Purchase Intention through Ecological Awareness and Perceived Consumer Effectiveness: An Empirical Investigation", *Frontiers in Environmental Science*, Vol. 10, 985200. <http://dx.doi.org/10.3389/fenvs.2022.985200>
57. Chepurna, M., Rialp Criado, J. (2021), "What motivates and deters users' online co-creation? The role of cultural and socio-demographic factors", *Spanish Journal of Marketing – ESIC*, Vol. 25 No. 2, pp.260-281. <https://doi.org/10.1108/SJME-10-2020-0176>
58. Witek, L., Kuzniar, W. (2021), "Green Purchase Behavior: The Effectiveness of Sociodemographic Variables for Explaining Green Purchases in Emerging Market", *Sustainability*, Vol. 13 No. 1, 209. <https://doi.org/10.3390/su13010209>
59. Sakkthivel, A. M. (2013), "Examining the impact of socio-cultural and psychographic/demographic variables on women consumer behaviour: an exploratory study from Arab League countries", *International Journal of Electronic Finance*, Vol. 7 No. 2, pp.161-175. <https://doi.org/10.1504/IJEF.2013.057268>
60. Santos, J. A. C., Fernández-Gámez, M. Á., Guevara-Plaza, A., Custódio Santos, M., Pestana, M. H. (2023), "The sustainable transformation of business events: sociodemographic variables as determinants of attitudes towards sustainable academic conferences", *International Journal of Event and Festival Management*, Vol. 14 No. 1, pp.1-22. <https://doi.org/10.1108/IJEFM-05-2022-0041>
61. Kamaruddin, A. R., Mokhlis, S., Othman, M. N. (2002), "Ethnocentrism Orientation and Choice Decisions of Malaysian Consumers: The Effects of SocioCultural and Demographic Factors", *Asia Pacific Management Review*, Vol. 7 No. 4, pp.555-574.
62. Fam, K-S., Brito, P. Q., Gadekar, M., Richard, J. E., Jargal, U., and Liu, W. (2019), "Consumer attitude towards sales promotion techniques: a multi-country study", *Asia Pacific Journal of Marketing and Logistics*, Vol. 31 No. 2, pp.437-463. <https://doi.org/10.1108/APJML-01-2018-0005>
63. Han, H., Hsu, L-T. J., Lee, J-S., Sheu, C. (2011), "Are lodging customers ready to go green? An examination of attitudes, demographics, and eco-friendly intentions", *International Journal of Hospitality Management*, Vol. 30 No. 2, pp.345-355. <https://doi.org/10.1016/j.ijhm.2010.07.008>
64. Rahman, M. S. (2012), "Dynamics of consumers' perception, demographic characteristics and consumers' behavior towards selection of a restaurant: an exploratory study on Dhaka city consumers", *Business Strategy Series*, Vol. 13 No. 2, pp.75-88. <https://doi.org/10.1108/17515631211205488>
65. Shahsavar, T., Kubeš, V., Baran, D. (2020), "Willingness to pay for eco-friendly furniture based on demographic factors", *Journal of Cleaner Production*, Vol. 250, 119466. <https://doi.org/10.1016/j.jclepro.2019.119466>
66. Kim, Y. J., Palakurthi, R., Hancer, M. (2012), "The Environmentally Friendly Programs in Hotels and Customers' Intention to Stay: An Online Survey Approach", *International Journal of Hospitality & Tourism Administration*, Vol. 13 No. 3, pp.195-214. <https://doi.org/10.1080/15256480.2012.698169>
67. Alharthey, B. K. (2019), "Impact of green marketing practices on consumer purchase intention and buying decision with demographic characteristics as moderator", *International Journal of Advanced and Applied Sciences*, Vol. 6 No. 3, pp.62-71. <https://doi.org/10.21833/ijaas.2019.03.010>
68. Sewwandi, J. P. N., Dinesha, P. K. C. (2022), "The impact of green marketing tools on green product purchase behavior: the moderation effect of consumer demographics" *Asian Journal of Marketing Management*, Vol. 1 No. 1, pp.89-114. <https://doi.org/10.31357/ajmm.v1i01.5469>
69. Sushil. (2012), "Interpreting the interpretive structural model", *Global Journal of Flexible Systems Management*, Vol. 13 No. 2, pp.87-106. <https://doi.org/10.1007/s40171-012-0008-3>
70. Ajzen, I., and Fishbein, M. (1980), *Understanding attitudes and predicting social behavior*, Prentice-Hall, Englewood-Cliffs

71. Fishbein, M., and Ajzen, I. (1975), *Belief, attitude, intention, and Behavior: An introduction to theory and research*, Addison-Wesley Publishing Co, Incv., Boston.

72. Ajzen, I. (1991), "The theory of planned behavior", *Organizational Behavior and Human Decision Processes*, Vol. 50 No. 2, pp.179–211. [https://doi.org/10.1016/0749-5978\(91\)90020-T](https://doi.org/10.1016/0749-5978(91)90020-T)

73. Ajzen, I. (2005), "Laws of human behavior: Symmetry, compatibility, and attitude-behavior correspondence".

74. Rezaei, G., Sumin, V., Mohamed, Z., Shamsudin, M. N., and Sharifuddin, J. (2016), "Implementing Green Practices as Sustainable Innovation Among Herbal-Based SME Entrepreneurs", *Journal of Food Products Marketing*, Vol. 22 No. 1, pp.1–18. <https://doi.org/10.1080/10454446.2015.1048030>

CONTEXTUALIZING ATTITUDE-INTENTION-BEHAVIOUR TRIAD WITH GREEN MARKETING & SUSTAINABLE PRACTICES: AN ISM APPROACH

Simran Babu, Sambalpur University, Burla, Sambalpur (India).

E-mail: simranbabu05@gmail.com

Saroj Kumar Sahoo, Sambalpur University, Odisha (India).

E-mail: sahoosaroj78@suniv.ac.in

Oleksandr A. Zadoia, Alfred Nobel University, Dnipro (Ukraine).

E-mail: o.zadoia@duan.edu.ua

<https://doi.org/10.32342/3041-2137-2025-2-63-14>

Keywords: *Purchase-behaviour, Intention, Attitude, Green-shopping, Sustainable-awareness, Socio-demographic*

JEL classification: *M31, M38, Q51, Q57*

Purpose: Although the relationship between behavioural intention and certain behaviour is a widely proven fact, the context in which this relationship develops has yet to be explored. Therefore, this study aims to examine the contextual relationship between green purchase behaviour and green purchase intention, customers' attitudes towards green shopping, customers' culture, customers' awareness of sustainable practices, perceived risk, and socio-demographic factors.

Research methodology & design: This study followed a qualitative approach, where the contextual relationships of the above-mentioned factors were studied with the ISM (Interpretive Structural Modelling) technique. An extensive literature review and opinions of some experts enabled the authors to establish the contextual relationships among the identified variables/elements.

Findings: The major findings indicate that green purchase behaviour is driven by the other aforementioned elements including the green purchase intention and attitude. The socio-demographic variables carry highest driving power, suggesting that these variables form the ground for abovementioned intention and behaviour.

Originality: The new structural model based on contextual relationships makes a significant contribution to the existing theories and concepts related to the attitude-intention-behaviours triad.

Practical & social implications: A clear understanding of the aforementioned triadic relationship can provide innovative pathways for marketing strategies, with maximum consideration for the economy and society at large. The newly developed model also provides strategic inputs to the public planners for sustainable practices in the society.

Limitations & Implications: Empirical testing of the model with psychometric properties can provide wider applicability of this study.

Дата надходження до редакції / Submitted: 22.10.2024

Дата прийняття до публікації / Accepted: 06.03.2025

Дата публікації / Published: 04.07.2025